

SWFcontract GRABER® VERTICAL BLINDS

Graber vertical blinds provide superior strength and exceptional performance with a wide choice of headrail and louver options. Features such as EZ-Open™ and One Touch® wand control allow customization for any project. The louver color palette reflects the trends of today's market place.

- Ultra-Vue™ headrail with self aligning carriers
- G-71 Super-Vue® headrail with pantograph spacing
- G-85 Dura-Vue® economical steel headrail
- Durable vinyl louvers offer superior light control and are easy to clean
- Solar fabric louvers with 5% openness minimize glare and block UV rays
- FR fabric louvers are available free hanging or inserted into a channel panel

Commitment and innovation...

For over 100 years SWF has been synonymous with quality and innovation due to our commitment to excellence. This fundamental principle drives the company's research and development teams to develop distinctive products that are both functional and fashionable.

Environmental consciousness...

SWF is committed to the practice of recycling materials and sustainable forest management providing for a manufacturing process that puts the preservation of our natural resources first. SWF continues to invest in new technology that minimizes the environmental impact of our operations.

Best Experience...

The heart and soul of the SWF difference is its commitment toward creating the "Best Experience" possible. From consultation through installation, every window treatment produced is followed through by excellent customer service. It's all about satisfaction and that is what truly sets us apart.



WINDOW COVERINGS

Product Features

GRABER® ULTRA-VUE™ VERTICAL BLINDS

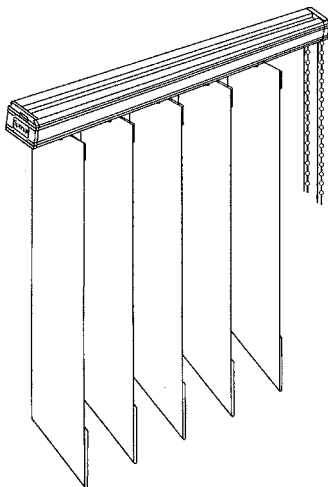

- Heavy duty anodized aluminum headrail - strength allows widths to 191"
- Self aligning carriers - eliminates misaligned louvers
- Slim carriers - provide tight stack for greater view
- Centrally located carrier stems - makes headrail reversible
- 6-1 gear ratio - provides effortless louver rotation
- Low friction wheeled carriers - allow louvers to traverse smoothly and easily
- One Touch® wand control optional - replaces chain and cord controls
- Lifetime warranty

Product Features

GRABER® G-71 SUPER-VUE® VERTICAL BLINDS

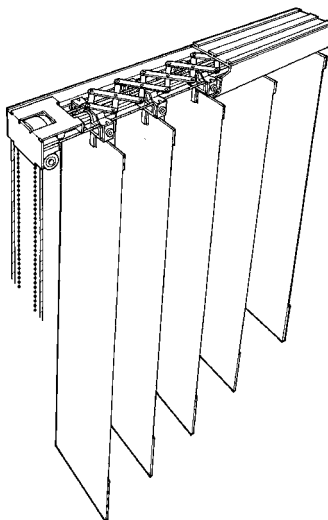

- Heavy duty anodized aluminum headrail - strength allows widths to 191"
- Steel pantograph - ensures precise and proportional louver spacing
- Rack and pinion gear system - allows louvers to rotate smoothly and easily
- E-Z Open™ automatic rotation - minimizes cord and chain confusion by automatically opening louvers before traversing
- Centrally located carrier stems - makes headrail reversible
- Specialty shapes - fits curved walls and angled windows
- One Touch® wand control optional - replaces chain and cord controls
- Lifetime warranty

Product Features

GRABER® G-85 DURA-VUE™ VERTICAL BLINDS

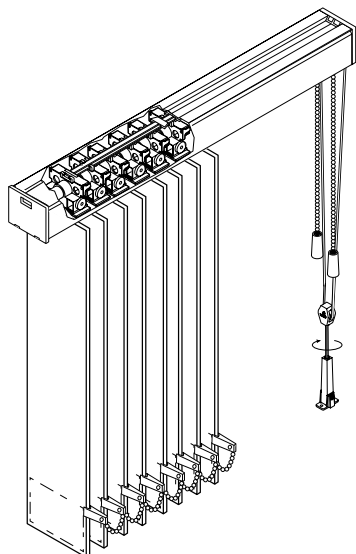

- Roll-formed steel headrail - strength allows widths to 191"
- Ivory painted finish - neutral appearance
- Wheeled carriers - allow louvers to traverse smoothly and easily
- Centrally located carrier stems - makes headrail reversible
- One Touch® wand control optional - replaces chain and cord controls
- Economically priced - dependable operation
- 10 year limited warranty