

DATA SHEET

Product Features

GRABER® 2" DESIGNER VINYL BLINDS

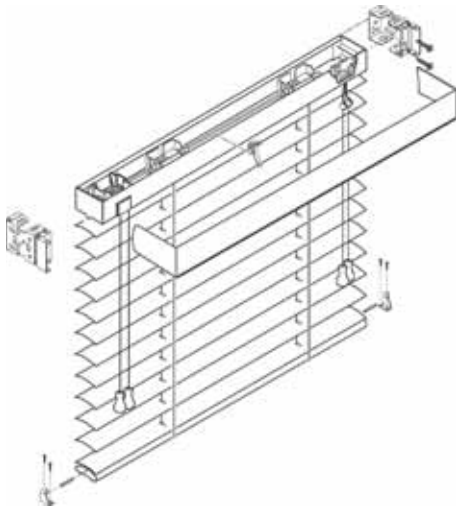

- 2" wide PVC crowned slats meet NFPA 701
- SureClose® headrail
- Cord tilt standard, want tilt option
- 1" and 1-1/2" cloth tapes option
- Coordinates with 3-1/2" PVC vertical louvers
- Lifetime headrail warranty

Product Specifications

GRABER® 2" DESIGNER VINYL BLINDS

SureClose® headrail shall be 1-5/8" high x 2-1/4" wide x .022" thick U-shaped steel with 1/8" light blocking lip on the bottom center line. The steel finishing process includes phosphate treatment for corrosion resistance, a chrome-free sealer, a low HAP urethane primer and a topcoat with low HAP polyester baked enamel.

Cord tilter shall be a snap-in component incorporating a worm and pulley of low-friction thermoplastic and nylon gear. Tilt cords shall be secured to pulley and treated with tassels at tilt end.

Tilt rod shall be electro-zinc coated solid steel measuring 1/4" square.

Cord lock shall be metal of a snap-in design incorporating a floating, shaft-type locking pin. Cord lock shall incorporate a crash proof safety feature that will lock blind automatically upon release of cord.

Drums shall be made of high strength thermoplastic, which securely anchors braided ladder or cloth tapes.

Installation brackets shall be a rivet-hinged front cover phosphate-treated steel with urethane primer and polyester baked enamel finish to match headrail.

Braided ladder shall be made of 100% polyester incorporating two extra strength rungs per ladder to support slats. Standard ladder spacing is 44mm.

Slats shall be rigid UV stabilized crowned PVC nominally 2" wide x .045" thick with straight cut edges. Slats meet the requirement of NFPA 701 Test Method 1-2004 edition.

Bottomrail shall be extruded foam PVC 9/16" high x 2" wide and shall coordinate with slats.

Options:

Wand tilter
Ring pull
Ring tilter
Extension brackets
Hold down brackets
Cut outs
Deluxe valance