

## DATA SHEET

## Product Features

## NANIK® 2" WOOD BLINDS

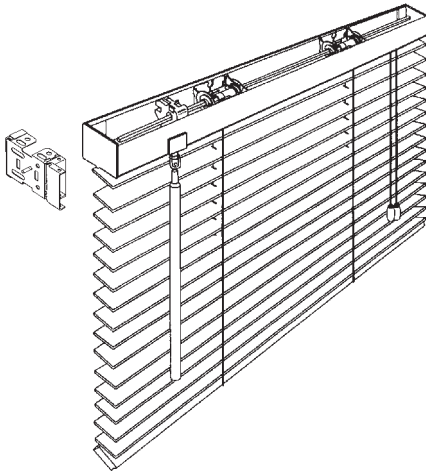

- Slats exclusively North American hardwood harvested through the practice of "sustained yield forest management"
- Clear satin finish
- Colors by Choice™ custom colors
- SureClose® XL headrail system
- Cloth tapes, decorative trims and beaded slat options
- Antique brass or wood tassels
- 1", 1-3/8" and 2-3/8" wide slat options
- Oversize blind capability
- Special shapes
- Lifetime warranty

## Product Specifications

## NANIK® 2" WOOD BLINDS

**SureClose®XL headrail** shall be 1-5/8" high x 2-3/8" wide x .055" thick U-shaped, extruded aluminum with 1/8" light blocking lip on the bottom center line and finished with a powder coat paint.

**Valance** shall be lineal grained, smooth sanded 100% North American basswood. Standard valance choices include a four bead, crown molded or a streamlined design.

**Tilter** shall be a cord operated worm and pulley design of low-friction thermoplastic and a nylon gear and housing.

**Tilt rod** shall be electro-zinc coated solid steel measuring 1/4" square.

**Cord lock** shall be of a snap-in design incorporating a floating, shaft-type locking pin and shall incorporate a crash proof safety feature that will lock blind automatically upon release of cord.

**Cradles** shall be made of molded nylon with a non-corrosive liner and guide for tilt cords.

**Braided ladder** roll shall be secured around the body of the ladder with a stainless steel wire loop. The ladder shall be secured to the tilt rod to ensure tight closure of slats.

**Braided ladder** shall be made of polyester Dacron yarn. Standard ladder spacing shall be 44mm.

**Installation brackets** shall be a rivet-hinged front cover phosphate-treated steel with urethane primer and polyester baked enamel finish to match headrail.

**Slats** shall be nominally 2" wide x .115" thick and made of lineal grained and smooth sanded 100% North American basswood, kilned dried to a 6%-10% moisture content to reduce warping. Slats shall be stained and coated with a clear satin lacquer finish for a hand-rubbed appearance. Stain hue may vary in intensity due to natural variations in wood texture and grain. Painted slats shall be finished to specified mil thickness and within 1.0 Delta of master color samples.

**Bottomrail** shall be contour molded to a shape of 3/8" x 1-3/8" with 1/8" radius rounded edges. Bottomrail shall be lineal grained and smooth sanded 100% North American basswood, kiln dried to a 6%-10% moisture content and cut prior to finishing.

**Options:**

Colors by Choice™ custom color program  
High gloss finish  
Classic 1" and 1-1/2" cloth tapes  
COM cloth tapes  
Antique brass or wood tassels  
NoHoles™ slats  
Wand tilt  
Simpull® tilt control  
Hold down brackets  
Extension brackets  
Cut outs  
Tension wire  
Specialty shapes include arches, angle top, circle, oval and trapezoid