

SWFcontract™ GRABER® TRADITIONS™ 2" COMPOSITE WOOD BLINDS

DATA SHEET

Product Features

GRABER® TRADITIONS™ 2" COMPOSITE WOOD BLINDS

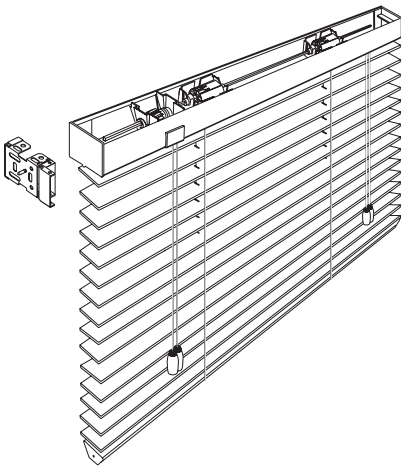

- PVC-free Polystyrene slats meet NFPA 701
- SureClose® headrail system
- Trapezoid shape bottomrail
- Authentic look of natural wood grain
- NoHoles™ option
- Cloth tape option
- 2-1/2" slat option
- 2-1/2" shutter style slat option
- Lifetime warranty

Product Specifications

GRABER® TRADITIONS™ 2" COMPOSITE WOOD BLINDS

SureClose® headrail shall be 1-5/8" high x 2-1/4" wide x .022" thick U-shaped steel with 1/8" light blocking lip on the bottom center line. The steel finishing process includes phosphate treatment for corrosion resistance, a chrome-free sealer, a low HAP urethane primer and a topcoat with low HAP polyester baked enamel.

Cord tilter shall be a snap-in component incorporating a worm and pulley of low-friction thermoplastic and nylon gear. Tilt cords shall be secured to pulley and treated with tassels at tilt end. Cord tilter is standard.

Tilt rod shall be electro-zinc coated solid steel measuring 1/4" square.

Cord lock shall be of a snap-in design incorporating a floating, shaft-type locking pin and shall incorporate a crash proof safety feature that will lock blind automatically upon release of cord.

Drums shall be made of high strength thermoplastic, which securely anchors braided ladder or cloth tapes.

Installation brackets shall be a rivet-hinged front cover phosphate-treated steel with urethane primer and polyester baked enamel finish to match headrail.

Braided ladder shall be made of 100% polyester incorporating two extra strength rungs per ladder to support slats. Standard ladder spacing is 44mm.

Slats shall be a blend of PVC-free Polystyrene measuring 2" wide x 1/8" thick with straight cut edges. Slats meet the requirement of NFPA 701 Test Method 1-2004 edition.

Bottomrail shall be a blend of PVC polymers 7/8" high x 2" wide in a trapezoid shape to improve closure and shall coordinate with slats.

Options:

2-1/2" slat
2-1/2" shutter style slat
NoHoles™ slat
Cloth tapes 1-1/2" or 1"
Wand tilter
Ring pull
Ring tilter
Extension brackets
Hold down brackets
Cut outs