

DATA SHEET

1" WOOD BLINDS

Product Features

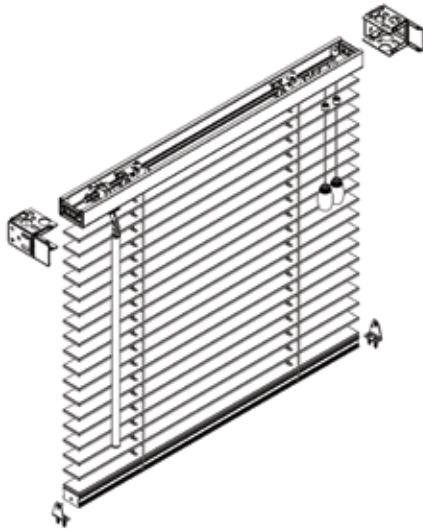

- **Slats made exclusively of North American hardwood**
- **Rectangular-shaped bottomrail**
- **Wand tilt**
- **Wood tassels**
- **Limited lifetime warranty**

Product Specifications

Headrail shall be 1" high x 1½" wide x .022" thick U-shaped steel. The steel finishing process includes phosphate treatment for corrosion resistance, a chrome-free sealer, a low HAP urethane primer, and a topcoat of low HAP, polyester-baked enamel.

Valance shall be lineal grained, smooth-sanded 100% North American Basswood. Valance choices include 3" Classic, 3½" Craftsman, 3½" Legacy, and 4½" Symphony.

Tilt wand shall be made of wood, finished to coordinate with the slats. Wands over 48" will be made of clear plastic.

Tilt rod shall be electro-zinc coated solid steel measuring .221" hexagonal.

Cordlock shall be of a snap-in design incorporating a stainless steel wear guard over which cords pass. A floating, shaft-locking pin will lock blind at any position and shall be crash proof. End of lift cords shall be treated with wood tassels.

Cradles shall be made of low-friction thermoplastic with metal lift cord rollers.

Drums shall be made of high-strength thermoplastic, which securely anchors braided ladder.

Braided ladder shall be made of 100% polyester yarn, incorporating two extra-strength rungs per ladder for slat support. Standard ladder spacing shall be 21.5 mm.

Cord shall be made of 100% polyester yarn and shall be 1.4 mm thick.

Installation brackets shall be a rivet-hinged front cover and made of phosphate-treated steel with urethane primer and polyester baked enamel finish to match headrail.

Slats shall be 1" wide x 1/8" thick, made of North American hardwood, kiln-dried to a 6%–10% moisture content to reduce the possibility of warping.

Bottomrail shall be 5/8" high x 1" wide wood in a rectangular shape and finished to coordinate with slats.

Options:

- Ring lift
- Ring tilt
- Extension brackets
- Hold down brackets
- Cut-outs
- Decorative tassels

The SWFcontract product presented is identical to Graber® Traditions® 1" Wood Blinds.